

Load Capacity Diagrams

E12

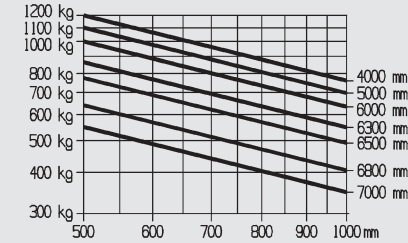

E14

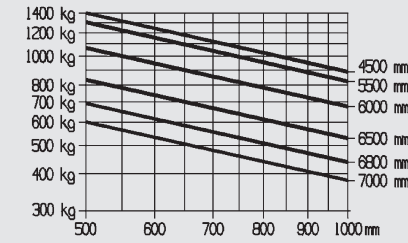

E15

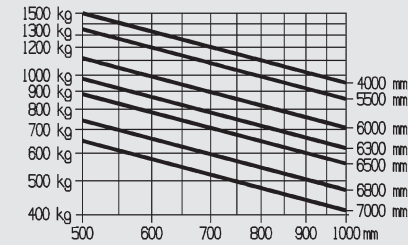

E16/E16C

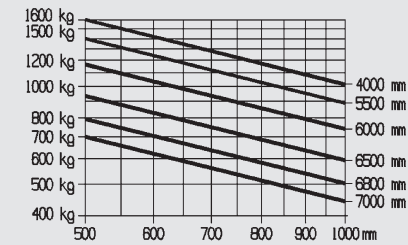

E16L/E16H

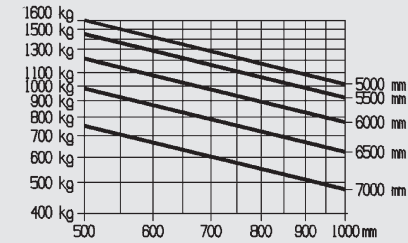

E18/E18L

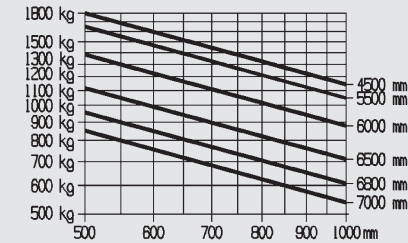

E20L

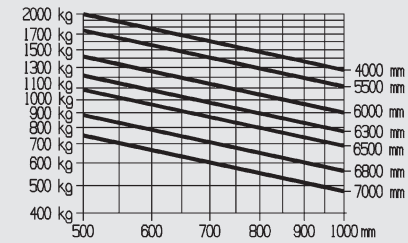

Standard Equipment/Optional Equipment

Standard Equipment

- Linde twin drive pedals to control forward/reverse travel and braking
- Original Linde Load Control integrated in armrest
- Hydraulic suspended seat with extensive range of adjustment
- Hydrostatic power steering
- Three wheel configuration with original Linde center-pivot axle for excellent manoeuvrability
- Linde compact drive axle with maintenance free oil-bath disc brake
- Famous Linde dual motor drive with 2 x 4,6 kW for 48 V models and 2 x 3,5 kW for the 24 V models
- 11 kW (48 V) maintenance free AC lift motor, 10 kW for 24 V models
- Curve Assist for automatic, proportional speed adaption
- Plenty of storage space for writing utensils, beverage cans ...
- Anti-glare display with clock, hour meter, service information and accurate battery condition indicator
- Standard truck fits into ISO containers
- Superelastic tyres

Optional Equipment

- Single drive pedal with direction selector on armrest
- Overhead guard can be upgraded to full cabin with roof, front-, rear screens and doors (also available with tinted glass)
- Wiper-washers for front, rear and roof screens
- Further seats with additional comfort and adjustments
- Cab heater with integrated pollen filter
- Radio with speakers
- Sun screen, clipboard and interior light
- Standard mast lifts up to 5650 mm
- Duplex mast (full free lift) lifts up to 4145 mm
- Triplex mast (full free lift) lifts up to 6075 mm
- Single or double additional hydraulics for all mast types
- Tilt cylinder- and roof protection
- Integrated sidseshift
- Integrated fork positioner
- Mirrors

- Battery capacity for low version (h6=1,970 mm): E12=24 V/575 Ah, E15=24 V/920 Ah, E14=48 V/460 Ah, E16=48 V/575 Ah, E16C=48 V/460 Ah, E16L=48 V/690 Ah, E18=48 V/575 Ah, E18L=48 V/690 Ah, E20L=48 V/690 Ah
- Battery capacity for high version with increased battery capacity (h6=2,130 mm): E16H=48 V/700 Ah

New STANDARD features for the EVO models:

- New seat/armrest generation for outstanding ergonomics
- Improved energy consumption
- Enhanced tractive force and climbing ability
- Self-activating parking brake
- Individual drive dynamic mode providing perfect combination of performance and efficiency
- Showing battery operating time by the minute
- Dust and dirt protected Linde Load Control
- Enlarged step-in for high models
- New diagnostic plug for fast service access
- Sensitive traction control for Linde dual motor drive

- Linde original Blue Spot
- Road traffic specification
- Load backrest
- Swivelseat
- 12 V socket
- Truck lighting, working lamps
- Cold store protection
- Custom paintwork
- Linde Fleet Management (LFM)
- Active ventilation while charging

Linde energy management

- Customized horizontal and vertical battery change incl. NEW hydraulic battery shift
- Built-in high frequency onboard charger for convenience and flexibility
- Recirculation of electrolyte

Other options available on request



Electric Counterbalanced Trucks
Capacity 1200 - 2000 kg
E12 EVO®, E14 EVO®, E15 EVO®
E16 EVO®, E18 EVO®, E20 EVO® 386_02



Safety

The protective overhead guard forms a strong and completely enclosed protective zone providing optimum structural integrity, safety and protection for the operator. The top mounted tilt cylinders provide seamless, smooth control of the tilt movements for excellent load stability in all operating conditions. This unique design also enables slimmer mast profiles to be fitted for outstanding visibility.

Performance

One would expect a high performance truck to have a high performance traction system – and that is exactly what the Linde compact drive axle and lift system delivers. Powerful motors and intelligent electronic control form an impressive power pack to deliver the highest levels of productivity.

Comfort

Consistently high levels of performance and efficiency for extended periods are only possible if the operator feels comfortable. The ergonomic layout of all the controls, the adjustability of the armrest and seat, Linde Load Control and twin accelerator pedals provide the best possible intuitive interface between the truck and the operator.

Reliability

An electric fork lift truck depends on reliable electronic systems. The Linde electronic control system provides a high level of reliability because of its dual circuit monitoring system and the sealed aluminium housing which provides total protection for the electronics from the ingress of dust and moisture.

Productivity

Effective in operation, efficient in reducing costs: the unique Linde energy management system ensures intelligent and economical consumption of energy. Energy can also be obtained quickly utilising the optional built-in charging unit or one of the five simple and rapid battery changing methods. The result: more uptime and increased productivity.

Features

Linde clearview mast design

- With top mounted tilt cylinders for seamless load control and stability
- Excellent view of load and surroundings through the robust yet slim mast profiles
- Nominal capacity retained to maximum lift heights
- High residual capacities in all applications
- Exceptionally stable



Linde hydrostatic power steering

- Minimal physical demands on the operator
- Compact ergonomically designed steering wheel
- Linde close coupled steer axle for outstanding manoeuvrability
- Less tyre stress

Linde twin accelerator control

- Seamless, rapid reversing without repositioning the feet
- Short pedal travel
- Fatigue-free working
- Increased throughput and performance

Linde Load Control

- Small tactile joystick integrated in an adjustable armrest
- Precise and effortless fingertip joystick control of all mast functions
- Safe and highly efficient load handling

Linde Dual Motor Drive

- Two powerful AC drive motors
- Seamless acceleration and variable torque characteristics
- Power moduls in DCB-technology for high performance and efficiency cooling



Linde operator's compartment

- Ergonomically designed for efficient, fatigue-free working
- Spacious operator's compartment with generous floor plate area
- Cushioned comfort – mast and drive axle are isolated from the chassis and cab by a unique resilient suspension system that absorbs shock loadings

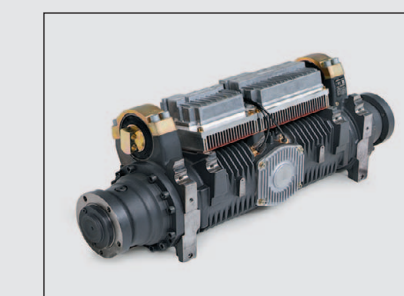

Linde compact drive axle

- Twin drive design with high performance Linde AC technology
- Integrated AC lift motor
- Optimum energy efficiency
- Maintenance-free oil-bath disc brake
- Efficient power moduls housed in sealed unit for complete protection
- Short, energy saving power connections



Linde energy management

- Optimised energy consumption
- Accurate battery condition indicator
- Simple horizontal or vertical battery changing options
- Optional built-in high frequency charger for convenience and flexibility
- Record of battery usage

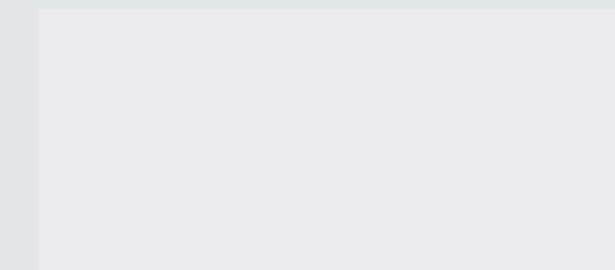

Linde Material Handling GmbH, Postfach 10 01 36, 63701 Aschaffenburg, Germany
Phone +49.6021.99-0, Fax +49.6021.99-1570, www.linde-mh.com, info@linde-mh.com



Subject to modification in the interest of progress. Illustrations and technical details could include options and not binding for actual constructions. All dimensions subject to usual tolerances.

Printed in Germany 102.E.3.02.14.indd.KI

Technical Data according to VDI 2198

Characteristics		LINDE											
		E12 (575Ah)	E15 (920Ah)	E14 (460Ah)	E16C (460Ah)	E16 (575Ah)	E16L (690Ah)	E16H (700Ah)	E18 (575Ah)	E18L (690Ah)	E20L (690Ah)		
1.1	Manufacturer	LINDE											
1.2	Model designation	E12 (575Ah)											
1.2a	Series	386-02											
1.3	Power unit	Battery											
1.4	Operation	Seat											
1.5	Load capacity	Q (t)	1.2	1.5	1.4	1.6	1.6	1.6	1.8	1.8	2.0		
1.6	Load centre	c (mm)	500	500	500	500	500	500	500	500	500		
1.8	Axle centre to fork face	x (mm)	365	365	365	365	365	365	370	370	374		
1.9	Wheelbase	y (mm)	1156 ¹⁾	1301 ¹⁾	1301 ¹⁾	1301 ¹⁾	1409 ¹⁾	1517 ¹⁾	1461 ¹⁾	1409 ¹⁾	1517 ¹⁾		
2.1	Service weight	(kg)	2805 ²⁾	2985 ²⁾	2890 ²⁾	3095 ²⁾	3060 ²⁾	3075 ²⁾	3340 ²⁾	3295 ²⁾	3335 ²⁾		
2.2	Axle load with load, front/rear	(kg)	3458 / 547	3912 / 573	3766 / 524	4099 / 596	4099 / 563	4112 / 563	4202 / 738	4466 / 629	4472 / 598		
2.3	Axle load without load, front/rear	(kg)	1360 / 1445 ²⁾	1415 / 1570 ²⁾	1435 / 1455 ²⁾	1435 / 1660 ²⁾	1515 / 1545 ²⁾	1600 / 1475 ²⁾	1655 / 1685 ²⁾	1555 / 1740 ²⁾	1640 / 1630 ²⁾		
3.1	Tyres rubber, SE, pneumatic, polyurethane		SE										
3.2	Tyre size, front		180/70-8 (18x7-8)										
3.3	Tyre size, rear		15x4 1/2-8										
3.5	Wheels, number front/rear (x = driven)		2x / 2										
3.6	Track width, front	b10 (mm)	930	930	930	930	930	930	930	965	965		
3.7	Track width, rear	b11 (mm)	168	168	168	168	168	172	172	172	172		
4.1	Mast/fork carriage tilt, forward/backward	a/b (°)	5.0 / 7.0										
4.2	Height of mast, lowered	h1 (mm)	2019	2019	2019	2019	2019	2019	2194	2019	2019		
4.3	Free lift	h2 (mm)	150	150	150	150	150	150	150	150	150		
4.4	Lift	h3 (mm)	2800	2800	2800	2800	2800	2800	3150	2800	2800		
4.5	Height of mast, extended	h4 (mm)	3401	3401	3401	3401	3401	3401	3751	3401	3401		
4.7	Height of overhead guard (cabin)	h6 (mm)	1970	1970	1970	1970	1970	1970	2130	1970	1970		
4.8	Height of seat/stand on platform	h7 (mm)	908	908	908	908	908	908	1065	908	908		
4.12	Towing coupling height	h10 (mm)	510	510	510	510	510	510	594	510	510		
4.19	Overall length	l1 (mm)	2601	2746	2746	2766	2854	2962	2906	2879	2967		
4.20	Length to fork face	l2 (mm)	1701	1846	1846	1866	1954	2062	2006	1979	2071		
4.21	Overall width	b1/b2 (mm)	1090 / 1050	1090 / 1050	1090 / 1050	1090 / 1050	1090 / 1050	1090 / 1050	1090 / 1050	1172 / 1050	1172 / 1050		
4.22	Fork dimensions	s/e/l (mm)	40 x 80 x 900										
4.23	Fork carriage to ISO 2328, class/type A, B		2A										
4.24	Width of fork carriage	b3 (mm)	980	980	980	980	980	980	980	980	980		
4.31	Ground clearance, below mast	m1 (mm)	89	89	89	89	92	97	97	97	97		
4.32	Ground clearance, centre of wheelbase	m2 (mm)	96	96	96	96	96	96	96	96	96		
4.33	Aisle width with pallet 1000 x 1200 across forks	Ast (mm)	3040 ³⁾	3177 ³⁾	3177 ³⁾	3196 ³⁾	3281 ³⁾	3389 ³⁾	3332 ³⁾	3305 ³⁾	3394 ³⁾		
4.34	Aisle width with pallet 800 x 1200 along forks	Ast (mm)	3164 ³⁾	3301 ³⁾	3301 ³⁾	3320 ³⁾	3405 ³⁾	3513 ³⁾	3456 ³⁾	3429 ³⁾	3518 ³⁾		
4.35	Turning radius	Wa (mm)	1349	1486	1486	1505	1590	1698	1641	1609	1698		
4.36	Minimum pivoting point distance	b13 (mm)	0	0	0	0	0	0	0	0	0		
5.1	Travel speed, with/without load	(km/h)	12.5 / 13.5										
5.2	Lifting speed, with/without load	(m/s)	0.3 / 0.5										
5.3	Lowering speed, with/without load	(m/s)	0.58 / 0.47										
5.5	Tractive force, with/without load	(N)	2400 / 2400										
5.6	Maximum tractive force, with/without load	(N)	7500 / 7500										
5.7	Climbing ability, with/without load	(%)	7.7 / 11.4										
5.8	Maximum climbing ability, with/without load	(%)	19.4 / 28.3										
5.9	Acceleration time, with/without load	(s)	5.8 / 5.0										
5.10	Service brake		hydr./mech.										
6.1	Drive motor, 60 minute rating	(kW)	2x 3.5										
6.2	Lift motor, rating at S3 15%	(kW)	5										
6.3	Battery according to DIN 43531/35/36 A,B,C,no		43 535 / A										
6.4	Battery voltage/rated capacity (5h)	(V/Ah)	24 / 575/625										
6.5	Battery weight (± 5%)	(kg)	708										
6.6	Power consumption according to VDI cycle	(kWh/h)	3.9										
8.1	Type of drive control		Digital/stepless										
8.2	Operating pressure for attachments	(bar)	170										
8.3	Oil flow for attachments	(l/min)	32										
8.4	Noise level at operator's ear	(dB(A))	< 65										

1) Mast in vertical position
2) Figures with battery, see line 6.4/6.5.
3) Including a 200 mm (min.) operating aisle clearance.

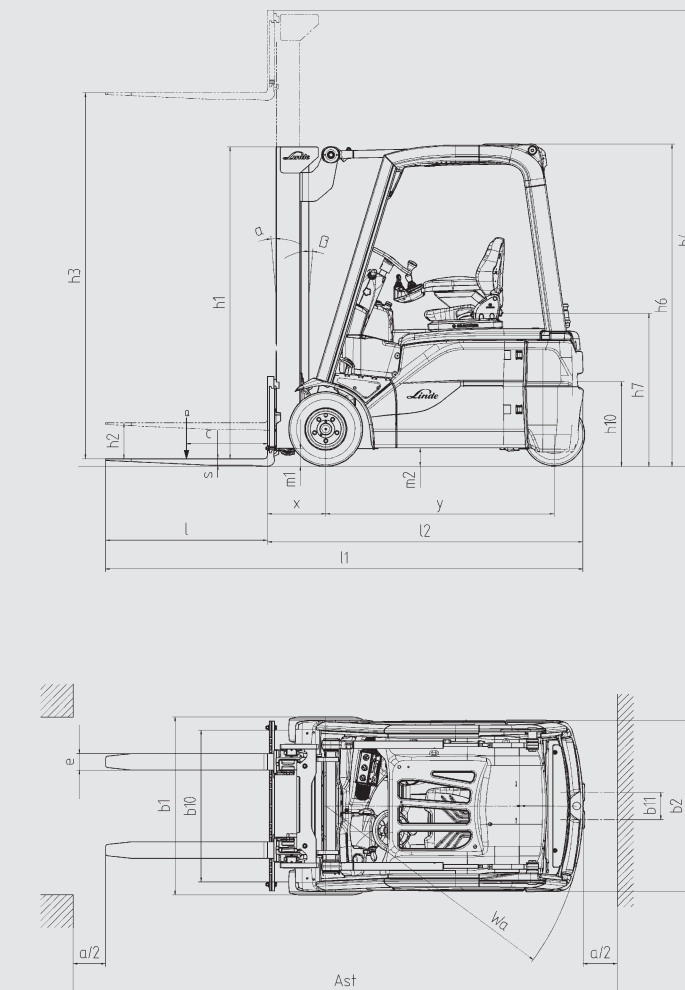

Standard mast (in mm)		E12/E14/E15/E16/E18 E16L/E18L/E20L				E16H	
Lift	h3	2800	3150	3850	4250	3150	3850
Overall height, retracted (to 150 mm free lift)	h1	2021	2196	2546	2746	2196	2546
Overall height extended	h4	3363	3713	4453	4813	3713	4453

Duplex mast (in mm)		E12/E14/E15/E16/E18 E16L/E18L/E20L				E16H	
Lift	h3	2795	3145	3845	-	3145	3845
Overall height, retracted	h1	1946	2121	2471	-	2121	2471
Overall height, extended	h4	3377	3727	4427	-	3727	4427
Special free lift	h2	1343	1518	1868	-	1518	1868

Triplex mast (in mm)		E12/E14/E15/E16/E18 E16L/E18L/E20L				E16H	
Lift	h3	4100	4625	5475	-	4625	5475
Overall height, retracted	h1	1946	2121	2471	-	2121	2471
Overall height, extended	h4	4702	5227	6077	-	5227	6077
Special free lift	h2	1344	1519	1781	-	1519	1781

Other lift heights on request
Minimum lift height does not apply to tall vehicle